



**Volume 25:4  
(October-December, 2025)**



# ***ICAR-CIPHET NEWS***



**ICAR-Central Institute of Post-Harvest Engineering and Technology  
P.O. Post Office, Ludhiana -141004, Punjab  
(An ISO 9001:2015 Certified Institute)**

**[www.ciphnet.in](http://www.ciphnet.in)**

*ICAR-CIPHET News 25:4, Oct-Dec 2025*



भाकृअनुप-सीफेट  
ICAR-CIPHET

**Published by:**

Director, ICAR-CIPHET  
P.O. PAU Ludhiana - 141004 (Punjab)  
Ph. No. 0161-23131103, 2313116  
Fax: 0161-2308670  
Website: <https://ciphnet.icar.gov.in/>  
E-mail: [hdtot.ciphnet@icar.gov.in](mailto:hdtot.ciphnet@icar.gov.in);  
[icarciphnetnewsletter@gmail.com](mailto:icarciphnetnewsletter@gmail.com)

**Editor in-Chief:**

Dr. Nachiket Kotwaliwale  
Director, ICAR-CIPHET

**Editors:**

Dr. Ranjeet Singh, Head, TOT Division  
Dr. Dhritiman Saha, Sr. Scientist  
Dr. Poonam Choudhary, Scientist  
Dr. ChandanSolanki, Scientist  
Dr. ArvindAhlawat, Head, KVK  
Dr. Rajiv Sharma, Technical Officer

**Assisted by:**

Harpreet Kaur, YP-I

**Contents**

| <b>Title</b>  | <b>Page no.</b> |
|---|-----------------|
| <b>Research Highlights</b>                              | 4               |
| <b>Publications</b>                                     | 14              |
| <b>ICAR-CIPHET Intellectual Property Rights</b>         | 16              |
| <b>Extension Activities</b>                             | 17              |
| <b>Human Resource Development and Capacity Building</b> | 20              |
| <b>Personalia</b>                                       | 25              |
| <b>Important Events</b>                                 | 25              |
| <b>Media Coverage</b>                                   | 31              |

## From the Director's Desk

Dear Stakeholder,



It is with immense pleasure and responsibility that I present the fourth quarterly report of the ICAR-CIPHET for the year 2025. The report reflects the cumulative impact of ICAR-CIPHET's extensive activities for advancing the agricultural processing sector through innovative research, need-based technology development, and focused capacity-building initiatives. During this quarter, the Institute intensified its efforts to address critical challenges in post-harvest management, adding value to agricultural products, and improving food processing systems. The technologies that the Institute developed and improved this quarter are in accordance with national priorities by focusing on: 1) Efficient use of resources, 2) Protecting and maintaining the environment and 3) Maximizing the value of agri-based products in the agri-supply chains through innovation.

A great deal of attention was paid to providing structured pathways for disseminating knowledge through specialized training programs, expert presentations, stakeholders consultations, and skill development workshops. These pathways were designed to increase the technical capabilities of farmers, agri-entrepreneurs, food technologists, food engineers, start-up businesses, and other stakeholders within the agri-value chain, thereby further encouraging innovation-driven rural and urban enterprises.

In parallel with its research and outreach activities, the Institute continued to make significant progress in strengthening its Intellectual Property (IP) portfolio through ongoing patent applications and technology protection measures, demonstrating its commitment to protecting the innovations produced through its scientific research.

Ludhiana, 2025

(NachiketKotwaliwale)  
Director, ICAR-CIPHET

## Research Highlights

### ICAR-CIPHET

#### ❖ Fibre-reinforced concrete bricks with varying reinforcement geometries

Under the CRP-NF project, M20 grade concrete paver blocks/bricks (8"× 8"× 80 mm) were developed with jute reinforcement arranged in different geometries, single, double, and triple mesh layers at specified depths, and alkali-treated scattered fibers at controlled dosages, to study the effect of reinforcement form and geometry on compressive behavior and crack control. The control blocks (Mark C) exhibited brittle failure with a mean compressive strength of 53.0 MPa. Jute mesh reinforcement modified both strength and failure mode: single-mesh specimens achieved 38.86 MPa (SMM), 47.40 MPa (SMU) and 44.44 MPa (SMB) with improved post-crack cohesion, while double-mesh layouts recorded 40.68 MPa (DM224), 45.78 MPa (DM422) and 49.16 MPa (DM242) with reduced spalling and better residual integrity. Scattered alkali-treated fibers produced strengths of 41.58 MPa (7.5 g), 57.44 MPa (15 g) and 42.92 MPa (22.5 g); the 15 g dosage yielded the highest strength and toughness, whereas higher fiber content reduced workability. The results confirm that both the geometry and quantity of jute reinforcement strongly influence paver block performance, with double/triple mesh arrangements and an optimized scattered fiber dosage (~15 g per block) providing the best balance of strength and post-peak toughness. Excess fiber content, although beneficial for crack bridging, adversely affects workability and compressive strength, indicating the need for optimization for practical applications.

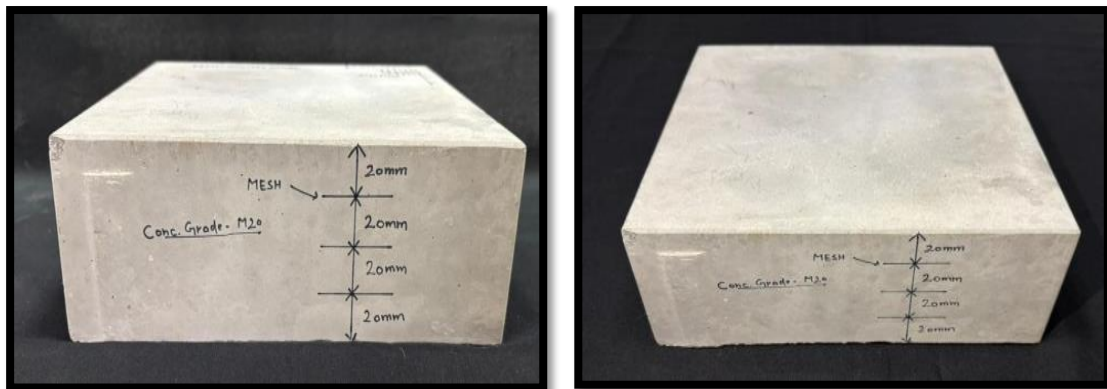

**Fibre-reinforced concrete bricks**

#### ❖ Structures for evaluation of RHA-based bricks

Under the CRP-NF project, three 10 × 10 ft room-sized masonry structures were constructed using RHA-based bricks (NINFET technology), fly ash bricks, and conventional burnt clay (red) bricks. The structures were comparatively evaluated under identical design, construction, and exposure conditions to assess structural performance, durability, and thermal comfort characteristics.

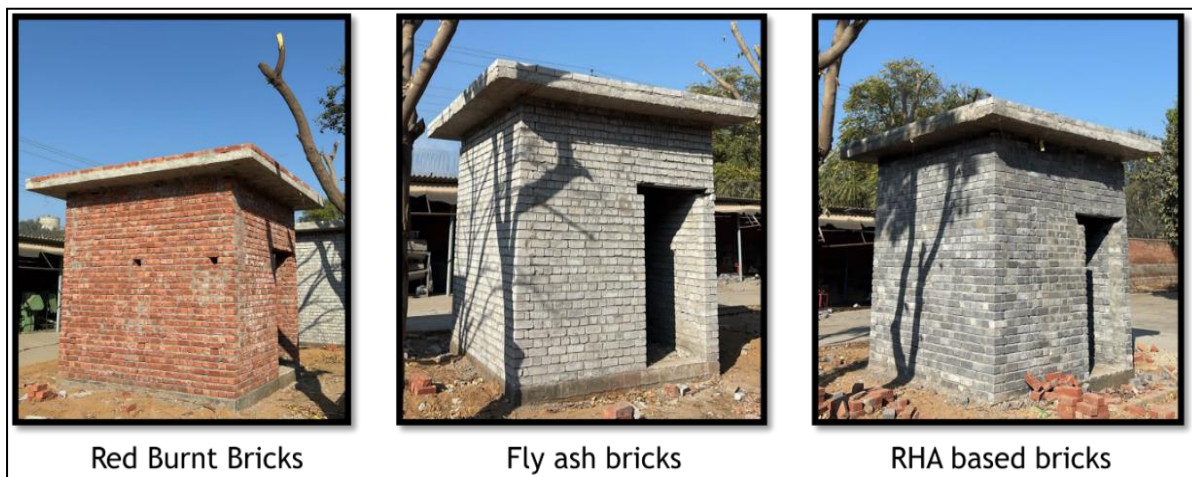

### ❖ Bioactive compounds from the *Ajwain* seeds

*Ajwain* (*Trachyspermum ammi* L.) seeds are rich in bioactive compounds, including phenolics, flavonoids, and essential oil constituents, particularly thymol, which contribute to their antioxidant, antimicrobial, and therapeutic properties. Efficient extraction of these bioactives is essential to enhance their functional potential for pharmaceutical and agrochemical applications. Experiments were conducted under the DBT project to optimize the extraction of bioactive compounds from ajwain seed powder using a conventional water-bath-assisted method. The study aimed to evaluate the effect of different solvents (water, ethanol, methanol, acetone, and diethyl ether), solute-to-solvent ratios (1:5, 1:10, 1:15 and 1:20), extraction durations (3, 4, 5, 6 and 7 hours) and temperature conditions (30, 40, 45, 50, 55, 60, 70 and 80°C) on the extraction efficiency. Throughout the extraction process, uniform agitation was maintained, and solvent evaporation was avoided, enabling comparison across different extraction conditions. Among the evaluated parameters, methanol demonstrated superior extraction performance compared to other solvents under all tested conditions. The highest extraction efficiency was observed at 55°C for 5 h, with a solute-to-solvent ratio of 1:15. Improved extraction efficiency with methanol could be attributed to its highly polar nature and strong solvating ability, facilitating methanol penetration into the matrix and the effective solubilization of bioactive compounds. Higher temperatures or excessively diluted ratios did not improve the yield but also led to degradation of phenolic compounds or reduced recovery. These findings highlighted that methanol-based extraction under moderate thermal conditions is the most promising approach for maximizing the recovery of bioactives in ajwain seed extract.

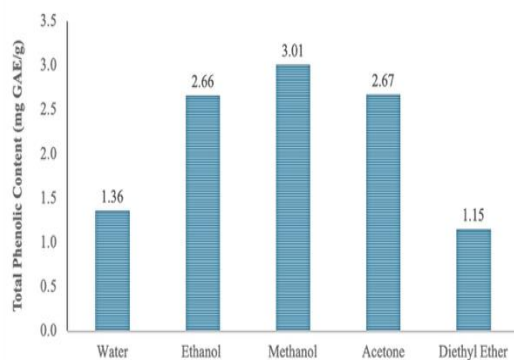

Effect of extraction solvents on total phenolic content

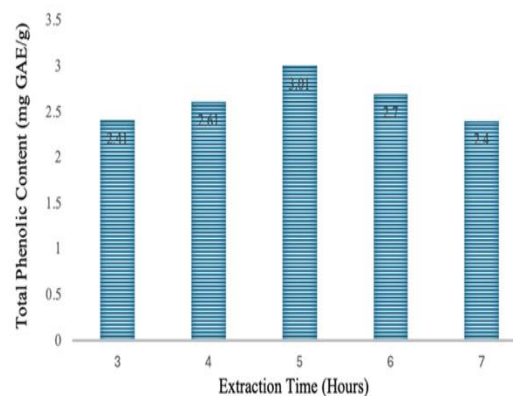

Effect of extraction time on total phenolic content

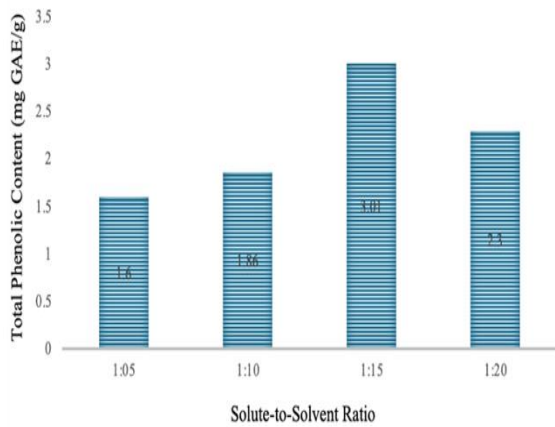

Effect of solute-to-solvent ratio on total phenolic content

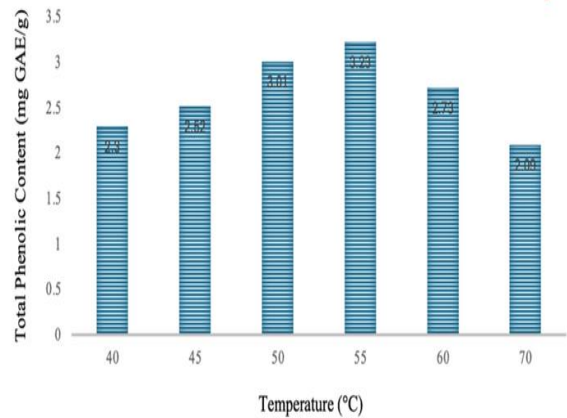

Effect of extraction temperatures on total phenolic content

❖ **Waterless live fish transportation**

Live fish not only provides consumers with fresh fish but also enhances unit cost realization for fish vendors. Fish vendors prefer transportation of live fish in water from the point of culture/capture to the point of sale. However, traditional water-based methods incur substantial costs due to increased loading capacity with water, biosecurity risks, and environmental concerns.

**Waterless Live Fish Transportation**

**Anaesthetized Rohu (n=10) survived without water for 4 hr. 37 min ± 27 min.**  
(Oxygen Surplus, Ambient Temp.)

**Waterless Live Fish Transportation System Design (Volume: 100 L)**

**Misting Unit to Increase DO for Extended Survival**



**Packaging: Food Grade LDPE bags; Fish Length 43±2 cm, 950±70 gm**



A transformative alternative, eliminating water usage through controlled hypothermia, anaesthetic sedation, and atmospheric optimization, was carried out in this study. Live Rohu (*Labeo rohita*) fish (total length: 20-35 cm, weight: 250-600 g each, n=10) were anaesthetized using chemical (natural: Clove Oil-1 mL/15 L water; synthetic: Benzocaine-50 mg/L water) and physical (gradient cooled water) anaesthetics, and their anesthetizing times for stage II anaesthesia and recovery times were compared. Anaesthetized live rohu fish were packed without water in a food-grade LDPE with surplus oxygen. anesthetizing time (min: sec) was significantly different, and the least for Clove Oil (02:55-03:30), followed by Benzocaine (03:33-20:00), and most for gradient cooled water (29:00-35:00).

However, recovery time (min: sec) was least for Benzocaine (1:24-2:58) followed by Clove Oil (05:10-06:15) and most for gradient cooled water (07:00-14:00). Anesthetized fish survived waterless for  $277 \pm 27$  min (04:37:00  $\pm$  00:27:00; hr.: min.: sec) (80%, n:10) in a waterless live fish transportation system. Results showed that live rohu fish can be transported waterless for about 5 hours. Survivability can further be extended by maintaining relative humidity (may be through misting), moist pads, minimal gill openings, etc.

## AICRP on PHET

### ❖ Nano sensor-based active packaging material integrated with carbon dots to monitor freshness of foods

Carbon quantum dots (CQDs) were successfully synthesized from sugarcane bagasse via hydrothermal treatment at 200 °C for 6 h, yielding a purified colloidal dispersion at TNAU, Coimbatore Centre. Contact angle measurements showed stable wetting behavior ( $\approx 55^\circ$ ) with low hysteresis (0.22–0.53°) for most samples, indicating uniform droplet interaction, while minor deviations in one sample suggested possible aggregation or surface heterogeneity. The droplet footprint remained consistent, demonstrating reliable deposition. These CQDs are being utilized to develop nanosensor-based active packaging materials for monitoring food freshness.

### ❖ Machinery and process protocol for value addition of palmyrah

The palmyrah fruit is rich in carbohydrates, dietary fiber, vitamins, carotenoids, flavonoids, and unique bioactives such as flabelliferins, yet remains underutilized due to its labor-intensive manual processing. The key engineering properties, such as bulk density (358 kg/m<sup>3</sup>), true density (527 kg/m<sup>3</sup>), porosity (32%), high sphericity (93.6%), and surface area (430 cm<sup>2</sup>) of fruits were studied at TNAU, Coimbatore Centre, to design the pulping and canning machinery. These insights can provide the information for the development of efficient processing equipment and protocols for value addition to palmyrah fruits. Palmyrah fruit has limited commercial use due to its difficult manual processing; hence, a cylindrical perforated pulper (1.4 × 0.77 × 0.41 m) was developed to facilitate efficient pulp extraction. Optimized blanching (60°C, 40 s) and retort processing (121°C, 15 min) improved the shelf life. During 12 weeks of storage, starch and major minerals declined, while protein, fibre, and trace minerals remained largely stable, preserving nutritional value.

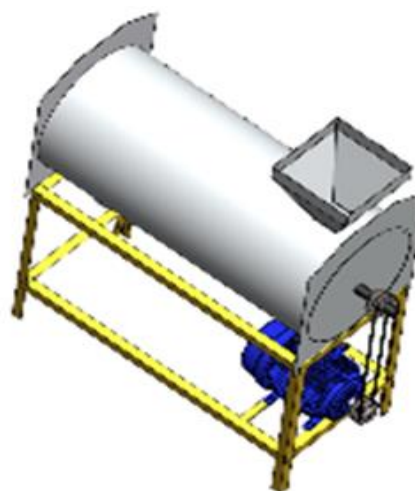

### ❖ Rice-based ready-to-eat food for the elderly

A nutritionally balanced and cost-effective rice-based ready-to-eat (RTE) food was developed at AAU, Jorhat, specifically formulated to meet the dietary needs of the elderly population in Assam. Using a Linear Programming (LP) model, the formulation was optimized to achieve an ideal balance between nutritional adequacy and cost efficiency, ensuring that essential nutrients were provided at minimal expense. The developed product can be reconstituted within 2-3 minutes with hot water, offering ease of preparation and convenience for elderly consumers.

It provides over 100% of the recommended daily intake of protein and vitamin C, supporting muscle maintenance and immune health, and has demonstrated excellent shelf stability for up to six months under ambient conditions. Priced at ₹70 per 50 g pack, this RTE formulation presents a nutrient-dense, affordable, and easy-to-consume meal option tailored for seniors, contributing to improved nutritional security and healthy ageing in the region.

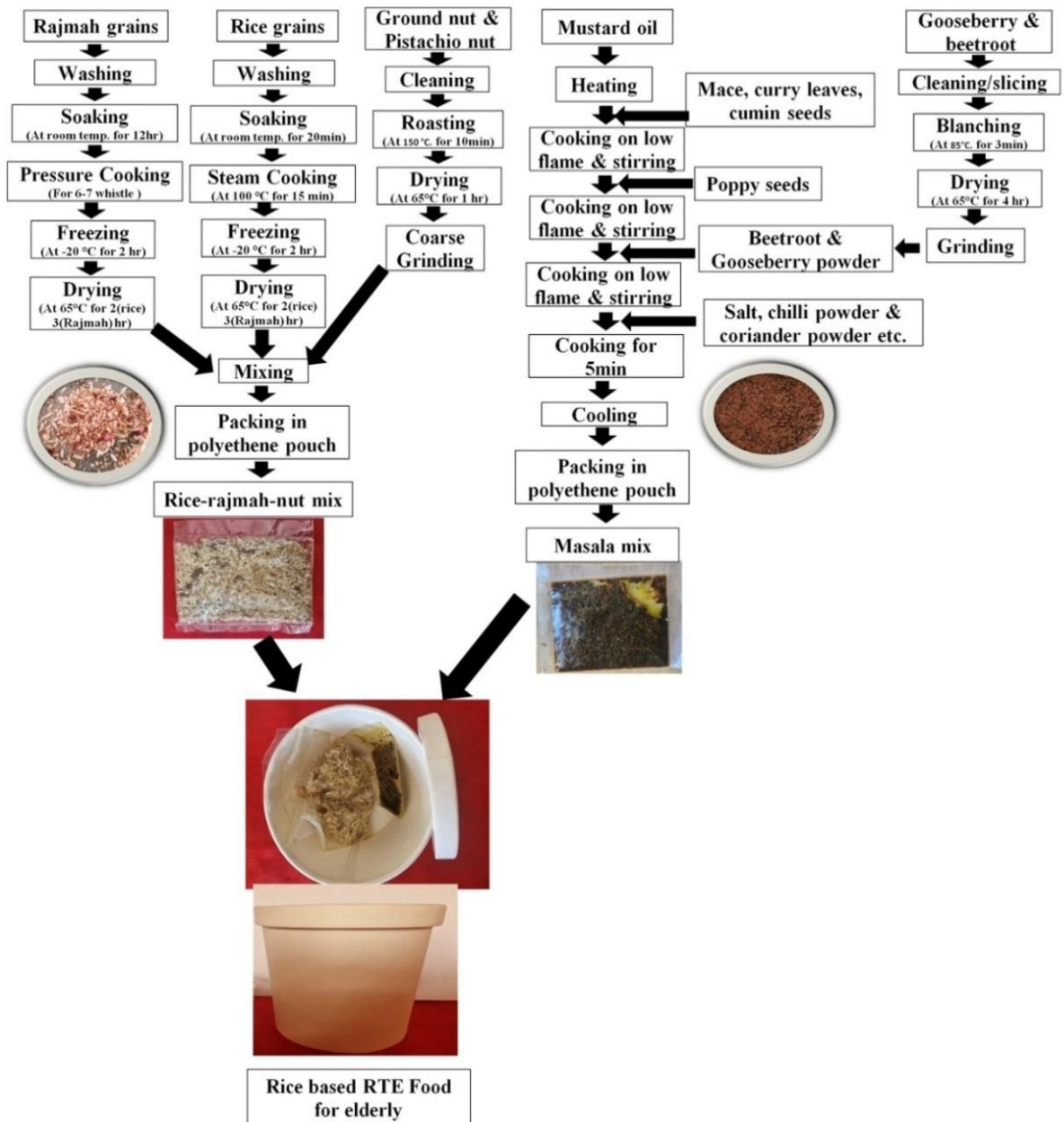

❖ **Antimicrobial resistance (AMR) in vegetable: Surveillance, prevalence and effective control using carbon dots derived from medicinal herbs**

Bacterial isolates from vegetables were screened for antibiotic susceptibility using the Kirby–Bauer disc diffusion method against 13 antibiotics at TNAU, Coimbatore Centre. Three isolates showed multi-drug resistance, particularly to Amoxicillin, Gentamicin, Streptomycin, Ciprofloxacin, Nalidixic Acid, Tetracycline, and Cefotaxime. All isolates tested negative for  $\alpha$ -amylase and  $\beta$ -hemolytic activity. This study supports surveillance of antimicrobial resistance and the development of carbon-dot-based interventions derived from medicinal herbs. Fruit (mango, sapota, guava) and vegetable (brinjal, bhendi, tomato, chilli) samples (500 g each) were collected from farmers’ fields at varied locations. A 25 g portion was homogenized in 225 ml BPW, then serially diluted, and plated on EMB, MacConkey, XLD, MSA, and BCA, followed by incubation at 37°C for 24–48 h. Distinct colonies were purified on LB agar and tested for antimicrobial susceptibility to different antibiotic classes.

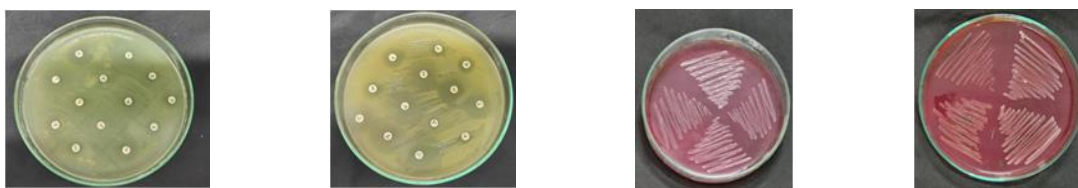

**Antimicrobial susceptibility test**

**$\beta$ -haemolytic activity**

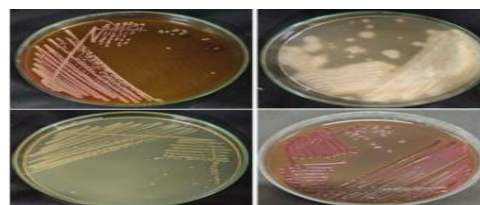

**Antimicrobial Resistance (AMR) in vegetables: Surveillance**

❖ **An osmo-sonicator for the production of osmo-dried temperate fruits and vegetables**

An Osmo-sonication process was developed for the production of osmo-dried temperate fruits and vegetables. The highest water loss ( $60.36 \pm 0.41$  %) was observed in osmo-sonicated samples treated with 10°B salt solution due to its strong osmotic gradient. However, despite higher mass transfer, the salt solution resulted in excessive salinity, nutrient leaching, and poor sensory acceptability. The smaller salt molecules and ultrasonic waves enhanced the leaching of bioactives. Hence, the sucrose solution was considered more suitable for the osmotic dehydration of mushroom slices.



**Difference in leaching causes by sucrose and salt slolutions**

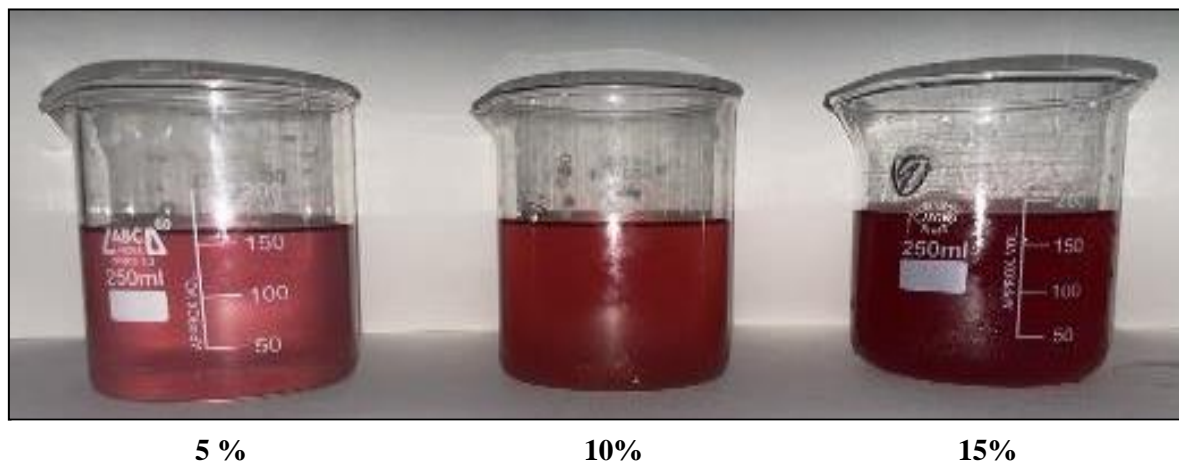

To enhance dehydration, rhododendron extract (5%, 10%, and 15% w/v) was prepared from dried pomace and used to make 55°B solutions. Mushroom slices were dehydrated using both osmotic dehydration and osmo-sonication. No significant variation in mass transfer was observed among the three extract concentrations. However, osmo-sonicated slices consistently showed greater water loss and solid gain than osmotically dehydrated slices.

#### ❖ Bioactive compounds from cocoa bean shells

Ultrasound-assisted extraction of cocoa bean shell (CBS) was optimized using Response Surface Methodology (RSM), revealing that temperature, substrate ratio, and extraction time significantly affected yield. The quadratic model ( $R^2 = 0.95$ ) reliably predicted extraction efficiency. Yield increased from 100 mg to 300 mg with higher temperature and longer time due to enhanced cavitation, solvent penetration, and mass transfer. Optimized ultrasound conditions thus improved bioactive compound recovery and process sustainability. Bioactive compounds were extracted from CBS using ultrasound-assisted extraction (UAE) with 70% ethanol at



**Cocoa bean shell bioactive extract incorporated cookies**

30°C for 1 h. The phenolic-rich extract was incorporated into butter cookies (1% CBS extract) to enhance antioxidant activity. Cookie preparation involved creaming butter and sugar, mixing with wheat flour, baking powder, salt, and vanilla, followed by the addition of the CBS extract. Dough was shaped and baked in an air fryer at 180°C for 20 min. The CBS-enriched cookies showed improved antioxidant properties and acceptable sensory quality, demonstrating a sustainable valorization of cocoa by-products into functional food ingredients. The ultrasound-assisted extraction (UAE) process of cocoa bean shell powder proved effective in extracting bioactive compounds. The extract enriched butter cookies with antioxidant properties without negatively affecting sensory attributes.

### ❖ Semi-continuous ozone treatment chamber for fresh-cut vegetables

A semi-continuous ozone treatment chamber was designed and fully fabricated based to treat fresh-cut vegetables. The system includes a stainless-steel conveyor connected to an ozone generator and an ozone analyzer-cum-destroyer. The complete setup consists of five main components: the ozone treatment chamber, the conveying system, the ozone generator, the ozone analyzer-destroyer, and the frame assembly. The fabricated chamber incorporated a stainless-steel wire-mesh belt (603 mm wide, 4.2 m long) with an MS roller chain and 25-tooth sprockets, enabling efficient semi-continuous ozone exposure for produce treatment. Using a Central Composite Design, the effects of ozone concentration (0.1–5 ppm) and exposure time (5–30 min) on the physicochemical properties of cut cauliflower were evaluated. Results showed that mild ozone treatment (0.1 ppm for 17.5 min) best preserved moisture (91.38%), color, and vitamin C (47.78 mg/100 g), while higher ozone levels (5 ppm for 5 min) caused slight oxidative degradation. Moderate treatment (3 ppm for 17.5 min) maintained intermediate quality, balancing nutritional retention and microbial control. During refrigerated storage ( $4 \pm 1^\circ\text{C}$ ), 5 ppm for 5 min provided the longest shelf life (up to 21 days) with minimal spoilage, while lower concentrations were less effective.



Results showed that mild ozone treatment (0.1 ppm for 17.5 min) best preserved moisture (91.38%), color, and vitamin C (47.78 mg/100 g), while higher ozone levels (5 ppm for 5 min) caused slight oxidative degradation. Moderate treatment (3 ppm for 17.5 min) maintained intermediate quality, balancing nutritional retention and microbial control. During refrigerated storage ( $4 \pm 1^\circ\text{C}$ ), 5 ppm for 5 min provided the longest shelf life (up to 21 days) with minimal spoilage, while lower concentrations were less effective.



Fresh-cut potato: No-treatment (control)



Fresh-cut potato: Ozone treatment

For potatoes, the fresh-cut potatoes were pre-soaked in 0.5% citric acid, and a Central Composite Design tested 1–5 ppm ozone for 5–30 minutes. It was observed that moisture content decreased with longer, higher-dose treatments, while water activity stayed stable (0.985–0.994). The color of cut potatoes was best at 3 ppm for 17.5 minutes (highest  $L^*$ ), whereas prolonged or high-dose ozone caused darkening or dehydration. During storage, the 3 ppm ozone treatment for 17.5 min kept potatoes lighter and firmer for up to two weeks. Overall, 3 ppm of ozone for 17.5 minutes was the most effective treatment for maintaining color and quality.

❖ **Lateral flow- assay-based rapid detection method for pathogens in foods of animal origin**

A rapid lateral flow-assay-based detection method was developed for the detection of pathogens in foods and animal origin. The final booster dose of the synthesized peptide injections for *E. coli* and *S. aureus* was administered to the rabbits, and terminal bleeding was performed on the 14<sup>th</sup> day to obtain the desired antibody titre for the assay. The ear vein bleed was performed on rabbits, and the obtained serum was subsequently used to check antibody titres using an in-house Indirect ELISA protocol; sufficient titres were found at serum dilutions greater than 1:800 for both *S. aureus* and *E. coli*.



**ELISA of *S.aureus* and *E.coli* showing reactivity upto serum dilution titres of 1:800**

❖ **Processing and value addition of karonda (*Carissa carandas*) fruit**

The power-operated karonda cutting machine was developed. The machine was evaluated using unripe fruits at feed rates of 16–20 kg/h and shaft speeds of 20–40 rpm. Cutting efficiency ranged from 79.36 to 96.00%, with the highest efficiency achieved at a feed rate of 18 kg/h and a spindle speed of 30 rpm. Higher feed rates beyond this reduced efficiency and increased damage, indicating optimal performance at moderate operating conditions.



**Karonda cutting machine**

**AICRP on PEASEM**

❖ **Development and characterization of bioplastic from rice straw cellulose**

A prototype mini plastic extruder was designed and developed at ICAR-CIPHET, Abohar, to enable the fabrication of bioplastic films from rice straw cellulose, thereby promoting sustainable utilization of agricultural residues and reducing environmental pollution from stubble burning. The developed extruder, with a processing capacity of 1–2 kg of raw material per hour, is suitable for both laboratory-scale research and small-scale pilot applications. It can be operated either by an electric motor for continuous extrusion or manually for controlled experimentation, ensuring uniform mixing, melting, and shaping of cellulose-based biopolymer composites.

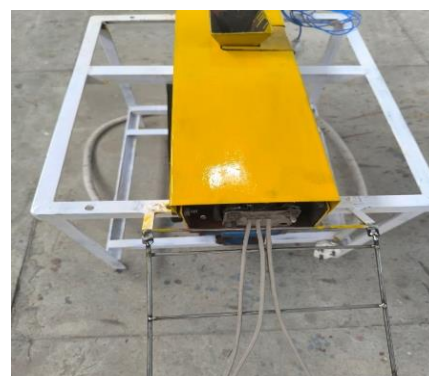

**Mini plastic extruder**

This development provides a platform for the systematic characterization of rice-straw-derived bioplastics in terms of mechanical, thermal, and barrier properties, supporting the production of biodegradable and compostable materials as potential substitutes for petroleum-based plastics and contributing to circular bioeconomy and eco-friendly packaging solutions.

❖ **IoT Aquaponic Monitoring System (Real-time environmental & nutrient analysis)**

In earlier Aquaponics systems, the need was felt for real-time monitoring of macro nutrients and other parameters. An interactive dashboard has been created to enhance the functionality of the IoT Aquaponic Monitoring System. By providing instant environmental and nutrient status updates, it helps optimize system performance and maintain a balanced aquaponic environment.

Link: <https://dayamangang.github.io/MyDashboard/> [ICAR-NEH, Barapani]

❖ **Development of plastic-lined loose boulder check dam**

A plastic-lined loose boulder check dam was developed and constructed by the Junagadh Centre to enhance rainwater harvesting efficiency and groundwater recharge in runoff-prone areas. The structure integrates locally available loose boulders with a durable plastic lining, which minimizes seepage losses and improves water retention capacity. The developed check dam can store approximately 1.66 m<sup>3</sup> of runoff water, making it an effective low-cost intervention for conserving surface water in small catchments. This innovation demonstrates the potential of combining conventional check dam designs with polymer-based lining materials to ensure sustainable water management, soil erosion control, and improved agricultural water availability in semi-arid and rainfed regions.

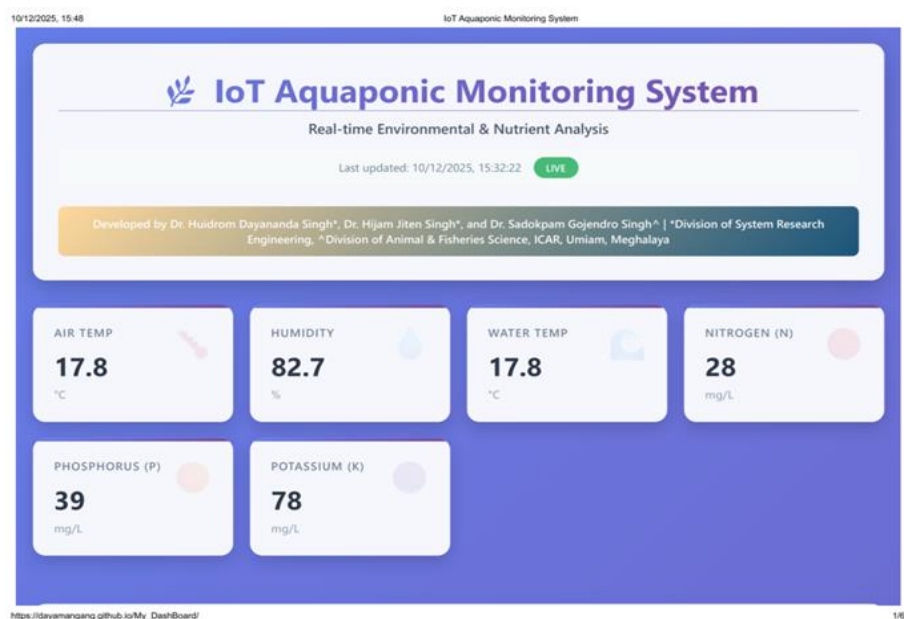

**Overflow of water on constructed dam**



**Plastic-lined Pond after harvesting of water from dam**

## Publications

### Research Articles

- Bala M, Bhinder S, Goswami D, Tushir S, Vishwakarma RK, and Kotwaliwale N (2025) Advances in dry fractionation techniques for enrichment. *Food and Bioprocess Technology*. Accepted.
- Bidyalakshmi T, Bala M, Tushir S, Kaur S, Kaur G, Mann S and Vishwakarma RK (2025) Unlocking the potential of chironji kernels: Role of packaging atmosphere and storage in nutritional and quality retention. *Journal of Food Measurement and Characterization*, Accepted.
- Dubey A, Mani I, Chandni RA, Nebapure SM, and Rudra SG (2025) Comparison of jute gunny bags with and without polypropylene for gram storage. *Journal of Stored Products Research*, 102881.
- Dubey, A, Nishani S, and Mann S (2025) Recent developments in passive daytime radiative cooling for enhancing sustainability in agro-food systems. *Sustainable Energy Technologies and Assessments*, 83, 104560.
- Gopaloreddy K, Khan H, Amaresh, Vinayaka, Lakshmi Pathy T, Gupta A, Mahendru-Singh A, Ahlawat AK, Patel JM, Birada SS, Mamrutha HM, Khobra R, Pandey V, Singh GP, and Tiwari R (2026) Deciphering low nitrogen tolerance of wheat in mega-environments using integrated multivariate approaches. *European Journal of Agronomy*, 173, 127919.
- Jadhav PR, Shabeer TA, Yadav RS, Dhole A, Kale RG, Raju DVS, and Kavar PG (2025) Comparative study on chemical characteristics of aromatic volatile organic compounds and gene expression in scented and non-scented *Rosa Hybrida* cultivars. *Physiology and Molecular Biology of Plants*, 1-15.
- Kairam N, Choudhary P, Arora M, and Sharma S (2025) Thermodynamic and kinetic studies of curcumin adsorption on corn cob powder. *Journal of Agricultural Engineering*, 62 (4).
- Kapoor, SA, Choudhary P, and Kasana RC (2025) Exploring CRISPR/Cas9-mediated gene editing advances in conventional and non-conventional yeast species. *Applied Biochemistry and Biotechnology*, 1-40.
- Mann, S., Tushir, S., Kaur, G., Devi, T.B., Sethi, S., Sahu, N., Bala, M, Vishwakarma, R.K. and Kotwaliwale, N., 2025. Harnessing the potential of underutilized *Buchanania lanzan* Spreng.: Review on processing, nutrition, and applications. *Indian Journal of Natural Products and Resources*, 16, 554-567.
- Tushir S, Yadav DN, Kapoor RK, Bala M, Mann S and Kataria K (2025) Evaluating the effect of desolventization temperature on de-oiled rice bran properties: Insights into flow, rheology, and its pasting behavior. *Journal of Food Measurement and Characterization*. Accepted.

### Book Chapters

- Rout RK, Kukde RB, Pakkirana S, Kumar A and Prakash R (2025) Methodology for extraction of essential oil using ultrasonic-microwave-assisted hydrodistillation. Essential oil extraction from food by-products, *Springer Protocols*, 183-217

- Saha D, Indore N, Devi TS, Kapri P (2026) Artificial intelligence, machine learning, and block chain approaches to plant-based protein linkages. *In Plant-Based Proteins Processing*, pp.385-400. Academic Press.

---

### Popular Articles

---

- Rupender Kaur, Ramesh Chand Kantwa, Arvind Kumar Ahlawat and Amit Nath (2025). Training Folder on Identification of food adulteration. ICAR-CIPHET, Ludhiana, Punjab.
- Rupender Kaur, Ramesh Chand Kantwa, Arvind Kumar Ahlawat and Amit Nath-Training Folder on Quality and safety guarantee-FSSAI and AgMark. ICAR-CIPHET, Ludhiana, Punjab.
- दवंगे संदीप , बेमबेम क. एवं मान संदीप (2025) मिलेट्स और अन्य अनाजों का मूल्यसंवर्धन एवं कृषि प्रसंस्करण केंद्र के माध्यम से प्रशिक्षण पुस्तिका –अनाज, मसाले एवं शहद प्रसंस्करण पर कौशल विकास 30सितम्बर04 अक्टूबर 2025 (सम्पादक: कुकड़े ,कौकब, कुमारी एवं सिंह), पृ .सं. 13-21.
- दीपिका गोस्वामी एवं चन्दन सोलंकी (2025) श्री अन्नकी कटाई के बाद प्रसंस्करण व मूल्यसंवर्धन हेतु तकनीकें | प्रशिक्षण पुस्तिका–अनाज,मसाले एवं शहद प्रसंस्करण पर कौशल विकास 30 सितम्बर04 अक्टूबर 2025 (कुकड़े ,कौकब, कुमारी एवं सिंहसम्पादक) पृ . सं 2-22.
- दीपिका गोस्वामी, शिवानी, कशिश कटारिया एवं लीनाकुमारी (2025) एक्सट्रूजन प्रौद्योगिकी द्वारा मक्का का प्रसंस्करण एवं मूल्यवर्धन| प्रशिक्षण पुस्तिका– कटाई उपरांत मक्का का प्रबंधन और मूल्यसंवर्धन अनुसूचितजाति उप-योजना, 30 सितम्बर04 अक्टूबर 2025 (कुमारी, कौकब, कुकड़े एवं रानी सम्पादक) पृ .सं .30-34|
- पंवार पंकज (2025). मक्का सुखाना हुआ आसान: भोजन, चारे और लाभ के लिए अपनी फसल की सुरक्षा| प्रशिक्षण पुस्तिका – कटाई उपरांत मक्का का प्रबंधन और मूल्यसंवर्धन अनुसूचित जाति उप-योजना, 4-7 अक्टूबर 2025 | (सम्पादक: कुमारी, कौकब, कुकड़े एवं रानी) पृ .सं .6-12.
- पवार पंकज (2025). क्रायोजेनिक पिसाई :मसालों के स्वाद और पोषण को बचाने की नई | प्रशिक्षण पुस्तिका–अनाज, मसाले एवं शहद प्रसंस्करण पर कौशल विकास 30सितम्बर 04 -अक्टूबर 2025 (सम्पादक: कुकड़े ,कौकब, कुमारी एवं सिंह), पृ .सं .40-42.
- मंजूबाला, दीपिका गोस्वामी और सूर्या तुषीर (2025) मक्का एवं श्री अन्न के मूल्य संवर्धन के लिए बेकिंग प्रौद्योगिकी | प्रशिक्षणपुस्तिका –कटाई उपरांत मक्का का प्रबंधन और मूल्यसंवर्धन - अनुसूचित जाति उप-योजना - अक्टूबर 2025 (सम्पादक: कुमारी, कौकब, कुकड़े एवं रानी) ,पृ .सं .48-58.
- महापात्रा सौम्या (2025). खाद्य प्रसंस्करण और मूल्यसंवर्धन में किसान उत्पादक संगठनों (एफपीओ) की भूमिका| प्रशिक्षण पुस्तिका–अनाज, मसाले एवं शहद प्रसंस्करण पर कौशल विकास 30सितम्बर 04 -अक्टूबर2025 (सम्पादक: कुकड़े ,कौकब, कुमारी एवं सिंह),पृ .सं .61-64.
- लीना कुमारी ,दीपिका गोस्वामी एवं शगफ कौकब (2025) मसालों में मिलावट :समस्या ,कारण ,प्रभाव और समाधान | प्रशिक्षणपुस्तिका - अनाज ,मसाले एवं शहद प्रसंस्करण पर कौशल विकास 30सितम्बर 04 -अक्टूबर2025 (सम्पादक: कुकड़े , कौकब, कुमारी एवं सिंह),पृ .सं| 47-43 .
- सिंह रणजीत (2025). शहद का मीठा विज्ञान: प्रसंस्करण और गुणवत्ता मूल्यांकन| प्रशिक्षण पुस्तिका - अनाज, मसाले एवं शहद प्रसंस्करण पर कौशल विकास 30सितम्बर 04 -अक्टूबर2025 (सम्पादक : कुकड़े ,कौकब, कुमारी एवं सिंह),पृ .सं .48-51.
- सुनीता थोंगम, बालकृष्णन रेनु. एवं बेमबेम क (2025). शहद का भंडारण और विपणन मूल्य श्रृंखला| प्रशिक्षण पुस्तिका – अनाज ,मसाले एवं शहद प्रसंस्करण पर कौशल विकास 30सितम्बर 04 -अक्टूबर2025 (सम्पादक : कुकड़े ,कौकब, कुमारी एवं सिंह),पृ . सं .56-60.

---

### Technical Bulletin

---

- Saha D, Thongam S (2025). Technical Bulletin on hyperspectral image analysis using machine learning on Google Colab (Python). ICAR-Central Institute of Post-Harvest Engineering and Technology, Ludhiana, Pp.1-72. Technical Bulletin No: ICAR-CIPHET/PUB/2025-26/02.

### Training manuals

- Guru PN, Solanki C, Bala M, Mann S, Choudhary P, Sethi S and Tushir S (2025) Gadgets for monitoring storage environment and quality. ICAR-Central Institute of Post-Harvest Engineering and Technology, Ludhiana (Punjab). pp. 64
- Patel K, Ahlawat AK and Nath A (2025) Training Manual on CRM at CIPHET, RS Abohar. ICAR-Central Institute of Post-Harvest Engineering and Technology, Ludhiana (Punjab). pp. 54
- Choudhary P, Bala M, Tushir S, Sethi S, Guru PN, Solanki C and Mann S (2025) Technical Bulletin on cosmetic products from the minor forest produce-Quality evaluation. ICAR-Central Institute of Post-Harvest Engineering and Technology, Ludhiana (Punjab). pp 92.
- Kaur R, Nath A and Kumar A (2025) Training Manual on Stitching techniques of fabric designing, RS Abohar. ICAR-CIPHET, Ludhiana, Punjab. Page- 83.
- Sethi S, Choudhary P, Tushir S, Bala M, Guru PN, Solanki C and Mann S (2025) Value-added products from Kodo, Kutki and Ragi Millets. ICAR-Central Institute of Post-Harvest Engineering and Technology, Ludhiana (Punjab). pp. 1-32
- कुकड़े रितु, कौकब शगफ़, कुमारी लीना एवं सिंह रणजीत (2025). एस.सी.एस.पी .योजना भारत सरकार के अंतर्गत अनाज, मसाले एवं शहद प्रसंस्करण पर कौशल विकास प्रशिक्षण हेतु प्रशिक्षण पुस्तिका, भाकृअनुप- केन्द्रीय कटाई उपरान्त अभियांत्रिकी एवं प्रौद्योगिकी संस्थान, लुधियाना-141004, पृ72
- कुमारी लीना, कौकब शगफ़, कुकड़े रितु, एवं सिंह रणजीत (2025).एस.सी.एस.पी .योजना भारत सरकार के अंतगत कटाई उपरान्त मक्का का प्रबंधन और मूल्य संवर्धन प्रशिक्षण पुस्तिका, भाकृअनुप - केन्द्रीय कटाई उपरान्त अभियांत्रिकी एवं प्रौद्योगिकी संस्थान, लुधियाना-141004, पृ .80
- मान संदीप, गोरेपति कल्याणी, श्री कृष्ण निशानी, दुबे अभिनव, प्रकाश रवि, दास राहुल, सिंह जीवनजोत (2025) प्याज के लिए कटाई उपरान्त प्रबंधन के उपाय, प्रशिक्षण पुस्तिका, भाकृअनुप - केन्द्रीय कटाई उपरान्त अभियांत्रिकी एवं प्रौद्योगिकी संस्थान, लुधियाना, पंजाब।

### ICAR-CIPHET Intellectual Property Rights

### Patents

| S. No. | Title   | Application No | Inventors  | Date    | Patent No. |
|--------|---|----------------|--|---------|------------|
| 1.     | Solar-powered mobile poultry processing cart (AICRP-PHET) (ICAR & Assam Agricultural University)                                      | 202511097033   | S Upadhyay<br>SK Laskar<br>Ankur Das<br>Protiva Gogoi<br>Deepshikha Deuri  | 8.10.25 | -          |
| 2.     | Reinforced clay pot smoking unit with integrated electric and smoke control system(AICRP-PHET) (ICAR & Assam Agricultural University) | 202511096795   | Ankur Das<br>SK Laskar,<br>S Upadhyay<br>Protiva Gogoi<br>Deepshikha Deuri | 8.10.25 | -          |

### Transfer of Technology

| S. No. | Technology  | Licensee/ Firm  | Licensing fee | Date     |
|--------|---|---|---------------|----------|
| 1      | Pearl millet based composite extrudates               | Ms. Sandhya Sahu Z-07, Empressia Earth E3, opposite Dunda Govt. School, Old dhamtari Road, Kandul, Raipur, 492013                                   | 0.50          | 18.11.25 |
| 2      | Process for Preparation of Fat Free Flavoured Makhana | Mr. Yash Roda, C/O Mr. Pawan Kumar Verma, D 54/16 B5/5, Luxa, Mari Mata Mandir, Chhitupur, PO: Mahmoorganj, District Varanasi, Uttar Pradesh-221010 | 0.50          | 18.11.25 |
|        |   | M/s A3S4 Food International, Shop No.3, G.N.E Colony, Ludhiana, Punjab-141013   | 0.50          | 03.12.25 |

### Extension Activities

#### Technology Demonstrations/ FLDs/OFTs

| S.No. | Technologies  | Venue            | Date     | Occasion                                    |
|-------|---|------------------|----------|---|
| 1.    | Extruded products from grains/maize   | CIPHET, Ludhiana | 01.10.25 | SCSP Training                               |
| 2.    | Extruded products from maize  | CIPHET, Ludhiana | 06.10.25 | SCSP Training                               |
| 3.    | AI based detection and localization model with robotic setup”                   | CIPHET, Ludhiana | 14.10.25 | Visit of Hon’ble MoS, MoA & FW and DG, ICAR |
| 4.    | 3D food printer and sensor based system for environmental monitoring of banana” | CIPHET, Ludhiana |          |   |
| 5.    | Autoclavable microencapsulation system  | CIPHET, Ludhiana |          |   |
| 6.    | On-Farm Maize cob drying system   | Bija Village     | 01.10.25 | Skill development programme                 |

### Mela/ Exhibitions

| S. No. | Programme title   | Venue                                    | Duration              |
|--------|---|--|-----------------------|
| 1.     | PAU Kisan Mela - 2025   | Punjab Agricultural University, Ludhiana | 26-27 September 2025  |
| 2.     | Mahila Kisan Diwas-2025   | PAMETI, PAU, Ludhiana                    | 15 October 2025       |
| 3.     | KVK-Fazilka-Kisan Mela  | RS, ICAR-CIPHET, Abohar                  | 18 October 2025       |
| 4.     | 1 <sup>st</sup> Nagaland Banana Festival 2025 cum National Workshop on Banana for Food-Fibre-Future | Wokha, Nagaland                          | 22 - 24, October 2025 |
| 5.     | Science-Technology-Defence-Space Exhibition organized by Ministry of Earth Sciences (MoES), GOI     | Dussehra Ground, Panchkula               | 6-9 December 2025     |

### Awareness programmes

| S. No. | Programme title  | Venue  | Date      |
|--------|--|--|-----------|
| 1.     | Block Level Program on CRM   | Sarain   | 23.9.2025 |
| 2.     | Village Level Program on CRM   | Gid dran Wali  | 25.9.2025 |
| 3.     | Awareness Program on Augmenting Oilseed Production: Empowering Farmers with New Technologies and Cluster Demonstration | Sardarpura   | 25.9.2025 |
| 4.     | Awareness program of FOM/LFOM  | Waryam Khera   | 26.9.2025 |
| 5.     | Block level program on CRM   | Sarain   | 23.9.2025 |
| 6.     | Mechanization for in-situ crop residue management (CRM)  | Tarn Taran   | 1 day     |
| 7.     | Mobilisation Camp on “Promotion of Agricultural Mechanisation for In-Situ Management of Crop Residue”                  | Shaheed Bhagat Singh State University (SBS-SU), Ferozepur. | 1 day     |
| 8.     | Crop Residue Management (CRM)  | KVK Amritsar   | 1 day     |
| 9.     | Paddy Residue Management   | Khalsa college for women, Amritsar                         | 1 day     |
| 10.    | Sustainable Crop Residue Management for climate resilient agriculture  | Guru Nanak Dev University, Amritsar                        | 1 day     |
| 11.    | Residue burning, crop residue management technique and viable alternatives available                                   | Chamaur Village, Rauni, Patiala                            | 07.11.25  |

|     |  |  |                       |
|-----|--|--|-----------------------|
| 12. | Crop residue management  | Kapurthala and Nawan Village   | 6.11.25 and 7.11.25   |
| 13. | Awareness program on crop residue management and ill effects of stubble burning  | Bhai Gurdas Group of Institutes and Govt. Senior Secondary Smart School, Ealwal, Sangrur | 7.11.25 and 11.11.25  |
| 14. | Sensitization program on CRM activities  | Govt. Senior Secondary Smart School, Samrala, Ludhiana                                   | 6.11.25               |
| 15. | Block-level camp on crop residue management                                      | Lapran Village Doraha Block, Samrala   | 14.11.25              |
| 16. | Awareness program on crop residue management                                     | Village Mallan and Muktsar   | 10.11.25              |
| 17. | Awareness program on CRM   | Jhumianwali  | 06.11.25              |
| 18. | Block level Program on CRM   | Basian   | 07.11.25              |
| 19. | Village-level program on CRM   | Mambeke  | 10.11.25              |
| 20. | Village-level program on CRM   | Mahatam Nagar  | 11.11.25              |
| 21. | Village-level program on CRM   | Rode   | 11.11.25              |
| 22. | Village-level program on CRM   | Samadh Bhai  | 12.11.25              |
| 23. | Awareness program on crop residue management                                     | Bhai Gurdas Group of Institutions, Sangrur   | 07.11.25              |
| 24. | CRM initiatives of ICAR-IIMR & ICAR-CIPHET                                       | KVK, Pathankot   | 14.11.25 and 15.11.25 |
| 25. | CRM initiatives of ICAR-IIMR & ICAR-CIPHET                                       | KVK, Ferozepur   | 14.11.25 and 15.11.25 |
| 26. | Block level Awareness Program on CRM   | Karni Khera  | 20.11.25              |
| 27. | Awareness cum training program on CFLD biofortified variety of wheat cultivation | KVK- Fazilka   | 20.11.25              |
| 28. | District level program on CRM  | Aliana   | 21.11.25              |
| 29. | Village level program on CRM   | Suresh Wala  | 24.11.25              |
| 30. | Village Level program on CRM   | Nihal Khera  | 25.11.25              |

### Stakeholder/ officer/ farmer/ exposure visits

| S. No. | Address of visitors                                  | Date       |
|--------|--|------------|
| 1.     | Entrepreneurs from village Kishangarh and Dharamgarh | 24.10.2025 |
| 2.     | Ryan International School, Ludhiana                  | 06.11.2025 |

|    |  |            |
|----|--|------------|
| 3. | Exposure visits by students from Lovely Professional University, Phagwara, Jalandhar | 18.11.2025 |
| 4. | Exposure visits by students from PAU, Ludhiana                                       | 20.11.2025 |
| 5. | Exposure visits by farmers, ATMA, Baran, Rajasthan                                   | 25.11.2025 |
| 6. | Exposure visits by trainee faculty IGMRI, Ludhiana                                   | 25.11.2025 |

### Human Resource Development and Capacity Building

#### Human Resource Development

| S. No. | Training title   | Venue                  | Duration            |
|--------|--|------------------------|---------------------|
| 1.     | Training Program on CRM  | KVK Fazilka, RS Abohar | 15.09.25 -19.09.25  |
| 2.     | Five days training on Management of Technology and Extension for Soil Testing Based Advisory Service to Farmer   | D.A.V College          | 15.09.25 -19.09.25  |
| 3.     | Post-Harvest Handling, Processing and Value Addition of Agricultural Commodities   | CIPHET, Ludhiana       | 18.9.25 - 03.10.25  |
| 4.     | Skill Development Training on Cereals, Spices and Honey Processing under SCSP Scheme (Govt. of India)  | CIPHET, Ludhiana       | 30.09.25 - 04.10.25 |
| 5.     | Post-Harvest Management and Value Addition of Maize under SCSP Scheme (Govt. of India)   | CIPHET, Ludhiana       | 04.10.25 - 07.10.25 |
| 6.     | Training Program on Post -harvest storage and packaging of fruits  | KVK Fazilka, RS Abohar | 22.09.25- 24.09.25  |
| 7.     | One Day Training Cum Awareness Program on CRM  | KVK Fazilka, RS Abohar | 24.09.25            |
| 8.     | One Day Training Cum Awareness Program on CRM  | KVK Fazilka, RS Abohar | 08.10.25            |
| 9.     | Post-Harvest Management and Value Addition of Minor Forest Produce<br><br>Phase-I: Hands on training for operation of various gadgets for storage environment monitoring and millet grain quality analysis<br><br>Phase-II: Preparation of novel | CIPHET, Ludhiana       | 22-29 October 2025  |

|     |   |                          |                   |
|-----|---|--------------------------|-------------------|
|     | products from millets and their quality testing<br>Phase-III: Quality evaluation of cosmetic products from the minor forest produce of Chhattisgarh state |                          |                   |
| 10. | Training on Bee keeping   | KVK Fazilka              | 11.11.25-13.11.25 |
| 11. | Processing of oilseeds for edible oil   | CIPHET, Ludhiana         | 26.11.25-28.11.25 |
| 12. | Drying of aonla for herbal applications   | RS, Abohar               | 8.12.25-10.12.25  |
| 13. | Training on Environment health and nutrition management through CRM   | KVK- Fazilka, RS, Abohar | 24.11.25-28.11.25 |
| 14. | Training on Value Addition Anola  | KVK- Fazilka, RS Abohar  | 01.12.25-06.12.25 |
| 15. | Training on Village Adoption program of NIFTM Students  | KVK- Fazilka, RS Abohar  | 19.11.25-27.11.25 |
| 16. | Training on the package and practice in the wheat crop and wheat distribution under the SCSP plan   | Aliana                   | 27.11.25-28.11.25 |

### Skill Development

| S. No. | Name                     | Title  | Venue                                   | Duration |
|--------|--------------------------|--|---|----------|
| 1.     | Shubham Rohilla          | Foundation Course  | NAARM-Hyderabad                         | 3 months |
| 2.     | Sawant Sanket<br>Ramnath | Foundation Course  | NAARM-Hyderabad                         | 3 months |
| 3.     | Priyanka Rahul<br>Kodag  | Foundation Course  | NAARM-Hyderabad                         | 3 months |
| 4.     | Sujata Sethi             | Training program for development of master trainers under Rashtriya Karmayogi Jan Seva Programme | Phase II,(Zone-IV) at ICAR-NDRI, Karnal | 3 days   |
| 5.     | Vikas Kumar              | Training program on Meta analysis under ICAR-NAARM   | ICAR-NAARM                              | 5days    |

|    |                        |                |              |        |
|----|------------------------|----------------|--------------|--------|
| 6. | Ramesh Chand<br>Kantwa | Drone training | PAU Ludhiana | 5 days |
|----|------------------------|----------------|--------------|--------|

### Awards/Recognition

| S. No | Name            | Name of Award  | Awarded from  |
|-------|-----------------|--|---|
| 1.    | Deepika Goswami | Best Scientist Award- 2025   | ICAR-CIPHET,<br>Ludhiana                            |
|       |                 | Second prize in Hindi kaavy paath pratiyogita under Rajbhasha Hindi Pakhwada-2025.   | ICAR-CIPHET,<br>Ludhiana                            |
|       |                 | Third prize in Chitr dekh kar kahaanee likho pratiyogita under Rajbhasha Hindi Pakhwada-2025.  | ICAR-CIPHET,<br>Ludhiana                            |
|       |                 | Consolation prize in Tatkaal bhaashan pratiyogita under Rajbhasha Hindi Pakhwada-2025.   | ICAR-CIPHET,<br>Ludhiana                            |
| 2.    | Poonam          | 3 <sup>rd</sup> price in Hindi Bhasha Gyan Prtiyogita  | ICAR-CIPHET,<br>Ludhiana                            |
| 3.    | Leena Kumari    | 2 <sup>nd</sup> prize, oral paper presented in राष्ट्रीय हिंदी वैज्ञानिक संगोष्ठी, हिंदी पखवाड़ा समारोह 2025 (Online)                        | ICAR - CIAE, Bhopal                                 |
| 4.    | Vikas Kumar     | हिंदी साहित्य के क्षेत्र में उत्कृष्ट योगदान हेतु साहित्य शिरोमणि सम्मान   | निर्मल रोशन साहित्यिक मंच,<br>न्यू जर्सी, अमेरिका   |
| 5.    | Guru PN         | ISAE Team award -2025  | ISAE, New Delhi                                     |
|       |                 | Best Oral Presentation award   | ICAR-CIAE, Bhopal                                   |
| 6.    | Amit Nath       | 3 <sup>rd</sup> award as “Best Exhibition Stall by Government Institutes” during the 1st Nagaland Banana Festival 2025 cum National Workshop | Deputy Commissioner,<br>Wokha, Govt. of<br>Nagaland |
| 7.    | Shilpa Selvan   | Best Scientist Award   | AICRP on PEASEM                                     |
|       |                 | Best oral presentation award (Frist prize)   | ISAE conference                                     |
| 8.    | Abhinav Dubey   | Young Scientist Award  | ICAR-CIPHET,<br>Ludhiana                            |
|       |                 | Food Innovations, Food Allergies and Traditional Foods” (FIFATF-2025) conference   | SLIET, Longowal.                                    |

**Participation in conference/ seminar/ symposia/ workshop/ meetings, etc.**

| S.No | Name   | Conference/ workshop/ etc  | Venue                                 | Date                          |
|------|--|--|---------------------------------------|-------------------------------|
| 1.   | Institute Scientists   | Swachhta pledge on Swachhta Hi Sewa - 2025   | CIPHET, Ludhiana                      | 17 September 2025             |
| 2.   |  | Brainstorming session with Dr. S. N. Jha, DDG (Agril. Engg.)   |                                       | 03 September 2025             |
| 3.   |  | CIPHET-IIFA-2025   |                                       | 04 September 2025             |
| 4.   |  | Meeting with Hon'ble State Minister and DG, ICAR   |                                       | 14 October 2025               |
| 5.   |  | Inauguration function of ICAR-IIMR Building, Ladowal.  | IIMR, Ludhiana                        | 14 October 2025               |
| 6.   |  | Guest lecture on quality, safety, and traceability in fish delivered by Prof. G. Jeyasekaran, Former Director of Research, Tamil Nadu Fisheries University, TN | CIPHET, Ludhiana                      | 09 October 2025               |
| 7.   |  | Inaugural and valedictory function of Hindi Pakwada 2025   |                                       | 12 and 29 September 2025      |
| 8.   |  | Stress management lecture  |                                       | 22 September 2025             |
| 9.   |  | Lecture on salary accounts and fraud prevention  |                                       | 24 September 2025             |
| 10.  | AK Ahlawat   | National Mission on edible oil and oil seeds   |                                       | State Agri Dept. Fazilka      |
|      |  | PMDDY  | ICAR, New Delhi                       | 11 October 2025               |
| 11.  | AK Ahlawat<br>KK Patel   | Scientist Farmer Interaction meeting on CRM  | ATARI, Ludhiana                       | 14 October 2025               |
| 12.  | Sumit Urhe   | Indo-Swedish workshop on Micro/nano sensors and their applications in environmental analysis   | BITS Pilani, KK Birla Goa campus, Goa | 15-16 October 2025            |
| 13.  | Guru PN<br>Rahul Yadav<br>Vikas Kumar<br>Pankaj Panwar<br>Sumit Urhe<br>Amit Nath<br>SS Selvan | 59 <sup>th</sup> Annual Convention on Engineering Innovations for Agriculture 5.0 and International Symposium  | CIAE, Bhopal                          | 10-12 November 2025           |
| 14.  | Amit Nath<br>SS Selvan   | Annual workshop  | AICRP on PEASEM                       | 29 October - 01 November 2025 |

|     |  |   |  |                                      |
|-----|--|---|--|--------------------------------------|
| 15. | Rupender Kaur  | Collaborative Seminar on Adolescent Girls' Health and nutrition awareness among adolescent girls                      | Govt. Girls SSS Smart School, Abohar         | 10 November 2025                     |
| 16. | Ravi Parkash,<br>Poonam<br>Sandeep Mann<br>S Nishani | One Day Workshop on Sustainable Rice Residue Management in Punjab   | IIIMR and CIPHET, Ludhiana                   | 28 October 2025                      |
| 17. | RK Anurag  | FAD 16 Foodgrains, Starches and Ready to Eat Foods to adopt ISO/TC 93 'Starch (including derivatives and by-products) | BIS, New Delhi                               | 14 November 2025                     |
|     |  | Innovations in Food Processing & Flavour Technologies: Advancing Safety, Nutrition and Health                         | International Life Sciences Institute-India  | 9 December 2025                      |
| 18. | Dhritiman Saha                                       | Invited talk on Food Innovations, Food Allergies, and Traditional Foods (FIFATF-2025)                                 | SLIET, Longowal                              | 11-12 December 2025                  |
| 19. | Prithvi Raj<br>Rupender Kaur                         | PMDDKY with state department and DC office, Fazilka   | DC Office                                    | 26 November 2025<br>28 November 2025 |
| 20. | Amit Nath  | Horticultural Innovations to Enhance Export from India  | NASC Complex, New Delhi                      | 28 November 2025                     |
| 21. | Rupender Kaur<br>A K Ahlawat<br>Rupender Kaur        | PMDDKY with state department and DC office, Fazilka   | DC office                                    | 30 November 2025<br>06 December 2025 |
| 22. | Shilpa S Selvan                                      | INTECH-2025 Innovations in Food Processing and Flavor Technologies Advancing Safety, Nutrition and Health             | International Life Sciences Institute India  | 09 December 2025                     |
| 23. | Deepika Goswami<br>Abhinav Dubey<br>S Nishani        | National Conference on "Food Innovations, Food Allergies and Traditional Foods"                                       | SLIET, Longowal                              | 11-12 December 2025                  |
| 24. | Maharishi Tomar                                      | Innovations in Food Processing & Flavor Technologies: Advancing Safety, Nutrition and Health                          | International Life Sciences Institute, India | 9 December 2025                      |

### Personalia

| S. No. | Name of the official      | Particular  | Designation                       |
|--------|---------------------------|-------------|-----------------------------------|
| 1.     | Sh. Rajesh Kumar          | Retired     | Assistant Chief Technical Officer |
| 2.     | Sh. Sughar Singh Verma    | Promoted    | Principal Private Secretary       |
| 3.     | Dr. Vijay Singh Sharnagat | Resigned    | Sr. Scientist                     |
| 4.     | Dr. Bhawna Kaliraman      | Joined      | Scientist                         |
| 5.     | Dr. Priyanka Rahul Kodag  | Transferred | Scientist                         |
| 6.     | Harender Singh Dahiya     | Transferred | SMS ( Agronomy )                  |

### Important Events

#### ❖ Industry interface fair on agro-processing (IIFA)-2025

The Central Institute of Post-Harvest Engineering and Technology (CIPHET) inaugurated CIPHET-IIFA 2025 industry interface fair on agro-processing on its 36th foundation day celebrations. The event was attended by Dr. SN Jha, Deputy Director General (Agricultural Engineering) and Dr. Narsaiah Kairam, Assistant Director General (Process Engineering), ICAR. The event attracted a diverse range of stakeholders including farmers, entrepreneurs, industrial representatives, researchers, students, and policymakers. The major primary goal of IIFA is to create a bridge between laboratory research and commercial application, enabling the dissemination and adoption of post-harvest and value-addition technologies developed by ICAR institutes and other research organizations across the country.



### ❖ ICAR–CIPHET, Ludhiana, hosts live broadcast of prime minister’s launch of landmark agricultural initiatives

ICAR–Central Institute of Post-Harvest Engineering and Technology (CIPHET), Ludhiana, organized a live viewing of the Hon’ble Prime Minister Shri Narendra Modi’s address delivered from IARI, Pusa, New Delhi. The event marked the unveiling of several transformative agricultural and allied-sector initiatives, collectively valued at more than ₹42,000 crore, aimed at accelerating India’s progress toward self-reliance in agriculture. During the national telecast, the Prime Minister unveiled two major flagship programmes – “PM Dhan Dhaanya Krishi Yojana” with a financial outlay of ₹24,000 crore to enhance agricultural productivity and irrigation infrastructure, and the “Mission for Aatmanirbharta in Pulses” worth ₹11,440 crore, focused on achieving self-sufficiency in pulse production through area expansion, seed improvement, and value-chain strengthening. In addition, the Prime Minister dedicated projects worth ₹5,450 crore to the nation and laid the foundation stones for new initiatives worth ₹815 crore, aimed at improving food processing, fisheries, animal husbandry, and post-harvest infrastructure. A total of 305 participants, including farmers, students and staff members of the institute, attended the program. On this occasion, Dr Nachiket Kotwaliwale, Director, ICAR-CIPHET, Ludhiana, appealed to the participants to stop burning of crop residues, crop damage and food wastage. After the program, the participants were shown various technologies developed in the Institute. Seeds, straw decomposers, organic fertilizers, and technical brochures of the Institute were also distributed to all the participants.



### ❖ Visit of Hon’ble Minister of State for Agriculture and Farmers Welfare, Government of India at ICAR-CIPHET, Ludhiana

Shri Bhagirath Chaudhary, Hon’ble Minister of State for Agriculture and Farmers Welfare, Government of India along with Dr. Mangi Lal Jat, Secretary, DARE and Director General, ICAR; Dr. S.N. Babu, Deputy Director General; and Dr. Rajbir Singh, Deputy Director General, visited the campus of the ICAR–Central Institute of Post-Harvest Engineering and Technology (CIPHET), Ludhiana. Dr. Nachiket Kotwaliwale, Director, ICAR-CIPHET welcomed the dignitaries and presented an overview of the institute’s achievements and its vital role in the field of post-harvest processing and value addition. The delegation was appraised of several innovative technologies developed by the institute, including modern dal mills, mycelium-based biodegradable materials, bajra processing machinery, portable plastic chowk dams, meat processing equipment, live fish transport systems, 3-D food printers, and sensor-based devices. The Minister also visited advanced laboratories and interacted with scientists and staff members.





Dr. Mangi Lal Jat, DG, ICAR, highlighted the critical role of post-harvest management and value-chain development in ensuring farmer's prosperity. He noted that while production is vital, true agricultural growth lies in linking farmers to markets and value chains, which enhances income and sustainability. He encouraged scientists to engage directly with farmers at the district level to understand their needs and develop farmer-centric technologies. He also called upon all scientists to align their efforts with the Government of India's vision of a "Viksit Bharat" through agricultural progress. The program concluded with a vote of thanks to all dignitaries and participants.

#### ❖ Pradhan mantri *Dhan-dhaanya* krishi yojana

Pradhan Mantri Dhan-Dhaanya Krishi Yojana Program was successfully organized at KVK Fazilka, ICAR-CIPHET, RS Abohar, on 11th October 2025. The event witnessed active participation from 364 farmers, reflecting strong grassroots interest in the scheme. The program aimed to inform and educate farmers about the benefits and implementation strategy of the newly launched Yojana, which focuses on enhancing agricultural productivity, input efficiency, and market linkages in underperforming districts. Experts from ICAR and KVK delivered



technical sessions on improved farming practices, seed-to-market integration, and the role of pulses in crop diversification under the *Dalhan Atmanirbhar* Mission.

#### ❖ Hindi pakhwada 2025

Dr. Maharishi Tomar, Chairperson Hindi Pakhwada 2025 successfully organized and oversaw Hindi Pakhwada activities with team from 14 to 28 September 2025, ensuring smooth planning, scheduling, and conduct of all events. The fortnight featured a comprehensive slate of activities poster competition, computer-based Hindi typing, Hindi translation (Anuvaad), Hindi essay writing, note drafting (Tippani), application drafting, Hindi poetry, extempore speech (Tatkal Bhashan), language knowledge quiz (Bhasha Gyan), Hindi article writing, and picture-based story writing. All programmes were executed as per schedule in a fair and disciplined manner, fostering wider use of Hindi in official work and cultural expression and reinforcing institutional commitment to the Rajbhasha.

### ❖ Mr. Cees Schoenmakers (PUM Senior Expert, Netherlands) visited ICAR-CIPHET

Mr. Cees Schoenmakers Visited ICAR- CIPHET during 7-15 November 2025 to discuss the strengthening of the ICAR-CIPHET's technology transfer and incubation system. He interacted with scientists, ABI/ITMU teams, and incubatees to understand current practices in incubation, mentoring, monitoring, and administrative processes. He visited the incubation partners, custom hiring centres, SHG food processing units, honey processing facilities, and incubation-related infrastructure at PAU & GADVASU. The field-level operations and stakeholder participation were reviewed through these visits. Mr. Cees then shared global insights on incubation methodology and provided suggestions to improve selection processes, coaching systems, partnerships, and revenue models. A draft advisory report was prepared and presented, containing key recommendations for upgrading the incubation ecosystem of ICAR-CIPHET.



Insights of visit of Mr. Cees Schoenmakers (PUM Senior Expert, Netherlands)

### ❖ Institute scientists participated in an awareness program organized on 'Crop residue management'

Institute Scientists actively participated in an awareness program on Crop Residue Management conducted from 1<sup>st</sup> to 15<sup>th</sup> November 2025. The program focused on educating farmers about sustainable alternatives to stubble burning, promoting in-situ and ex-situ residue management practices, and demonstrating the use of appropriate machinery and decomposer techniques. Through field visits, farmer meetings, and practical demonstrations, valuable guidance was provided on improving soil health, reducing environmental pollution, and enhancing crop productivity. The initiative significantly increased farmer awareness and encouraged the adoption of eco-friendly residue management practices in the region.



Apart from this, ICAR-CIPHET's KVK-Fazilka organized a CRM Mela on 18<sup>th</sup> October 2025, which attracted enthusiastic participation from more than 1000 farmers across the district. The program focused on promoting Crop Residue Management (CRM) and creating awareness about the harmful effects of stubble burning on soil health and the environment. Experts delivered informative lectures on the use of CRM machinery, sustainable agricultural practices, and government support schemes available to farmers. Demonstrations of modern CRM equipment further helped farmers to understand practical methods of residue management. Overall, the event successfully motivated farmers to adopt eco-friendly practices and contribute to cleaner, healthier farming systems.



#### ❖ Rashtriya Ekta Diwas

The Birth Anniversary of Sardar Vallabhbhai Patel is celebrated across the country on 31<sup>st</sup> October as Rashtriya Ekta Diwas (National Unity Day) to commemorate his invaluable contribution to the unity, integrity, and security of India. As part of the remembrance, the KVK Fazilka delivered the Rashtriya Ekta Pledge, a Video play, and Lectures on the role of Sardar Vallabhbhai Patel for the Nation. A total of 37 participants (35 male, 2 female) were present for the meeting.



#### ❖ Live Webcast of Pradhan Mantri Dhan Dhanya Krishi Yojana (PM-DDKY) at ICAR-CIPHET, Ludhiana

Scientists of ICAR–Central Institute of Post-Harvest Engineering and Technology (ICAR-CIPHET), Ludhiana, attended the live webcast of Pradhan Mantri Dhan Dhanya Krishi Yojana (PM-DDKY) on 19 November 2025. Pradhan Mantri Dhan Dhanya Krishi Yojana (PM-DDKY) is a flagship initiative of the Government of India aimed at enhancing farmers' income through integrated agricultural development, improved productivity, value addition, and efficient post-harvest management. The scheme focuses on strengthening agri-infrastructure, promoting modern technologies, and ensuring sustainable and inclusive growth in the agriculture sector. The webcast provided valuable insights into the objectives, scope, and implementation strategies of the scheme aimed at enhancing farmers' income, strengthening agricultural infrastructure, and promoting sustainable agricultural practices. The programme helped the participants to understand the policy framework and its potential implications for agricultural development and technology dissemination.



❖ **Interaction Programme with Hon'ble Vice Chancellor, SVPUAT, Meerut at ICAR-CIPHET, Ludhiana**

Scientists of the ICAR–Central Institute of Post-Harvest Engineering and Technology (ICAR-CIPHET), Ludhiana, attended an interaction programme with Dr. K.K. Singh, Hon'ble Vice Chancellor, Sardar Vallabhbhai Patel University of Agriculture and Technology (SVPUAT), Meerut, Uttar Pradesh, during his visit to the Institute on 20<sup>th</sup> November 2025. Dr. K.K. Singh, Hon'ble Vice Chancellor of SVPUAT, Meerut, is a distinguished agricultural scientist and accomplished academic administrator with extensive experience in agricultural research, education, and institutional leadership. The programme served as a valuable platform for deliberations on strengthening research collaboration, promoting knowledge exchange, and exploring joint initiatives in agricultural engineering, post-harvest management, and technology transfer. The interaction enabled the sharing of experiences and perspectives to enhance institutional cooperation and contribute to agricultural development.



❖ **Agricultural Innovation and Farmer Awareness Program Organized at KVK Abohar with PM-Kishan Saman Nidhi Yojana**

The program commenced with a welcome address by Dr. Amit Nath, Head of the Regional Centre, CIPHET Abohar on 19<sup>th</sup> November 2025. He provided detailed information about the PM-KISAN Samman Nidhi scheme, its benefits, and the financial assistance mechanism being provided to farmers. Dr. Rupinder Kaur highlighted the contribution of KVK to the economic development of rural women through its various activities, facilities, and training programs for farmers. Dr. Ramesh Kumar Kantwa delivered a lecture on the management and value addition of horticultural crops. Dr. Prakash Chand Gurjar provided information on soil health management. Dr. Kishan Kumar Patel lectured on the CRM machinery available at KVK and its uses. Mr. Prithviraj and Mr. Harendra Singh Dahiya held an open discussion with farmers on the problems faced during the cropping season. Following this, from 2:30 PM to 3:00 PM, the live webcast of the Hon'ble Prime Minister's message and program related to the Pradhan Mantri Kisan Samman Nidhi (PM-KISAN) scheme was viewed. The chief guest of the program was Dr. P. K. Nema, Professor and Dean, Students Welfare, National Institute of Food Technology Entrepreneurship and Management (NIFTEM-K), Kundli-Sonipat, who interacted with the farmers and emphasized the role of innovation and research in agricultural transformation. Finally, a vote of thanks was presented by Mr. Prithviraj. A total of 233 farmers enthusiastically participated in the entire event, making the program a success, and a resolution was passed to organize more effective programs in the future for the benefit of the farmers.



# केवीके में कृषि नवाचार व किसान जागरूकता कार्यक्रम

**सवेरा न्यूज/कथुरिया**  
अबोहर, 19 नवंबर : पीएम-किसान वेबकास्ट के साथ केवीके में कृषि नवाचार व किसान जागरूकता कार्यक्रम का आयोजन किया गया। कार्यक्रम का शुभारंभ क्षेत्रीय केंद्र सीफेट के प्रमुख डॉ. अमित नाथ के स्वागत भाषण के साथ हुआ। उन्होंने पीएम-किसान सम्मान निधि योजना को रूपरेखा, लाभ व किसानों तक पहुंचाए जा रहे आर्थिक सहायता तंत्र के बारे में विस्तार से जानकारी दी। डॉ. स्पेंडर कोर ने केवीके की विभिन्न गतिविधियों, सुविधाओं एवं किसानों को दिदि जाने वाले प्रशिक्षणों द्वारा ग्रामीण महिलाओं के आर्थिक विकास पर केवीके के योगदान पर प्रकाश डाला। डॉ. रमेश कुमार कांटवा ने उद्यान फसलों के प्रबंधन एवं मूल्य संवर्धन पर व्याख्यान



कार्यक्रम में उपस्थित किसानों के साथ मौजूद अधिकारी।

दिया। डॉ. प्रकाश चंद गुजर द्वारा मृदा स्वास्थ्य प्रबंधन पर जानकारी दी गई। डॉ. किशन कुमार पटेल ने केवीके में उपलब्ध सोआरएम, मशीनरी तथा उसके उपयोग पर व्याख्यान दिया। पृथ्वीराज व हरदर सिंह दाहिया ने किसानों के साथ फसल मौसम के दौरान आने वाली समस्याओं पर खुली चर्चा की। इसके उपरांत दोपहर 2.30 से 3 बजे तक प्रधानमंत्री किसान सम्मान

निधि योजना से संबंधित प्रधानमंत्री का संदेश और कार्यक्रम का लाइव वेबकास्ट देखा गया। कार्यक्रम के मुख्य अतिथि डॉ. पी. के. नेमा, प्रोफेसर एवं डीन, स्टूडेंट्स वेलफेयर, राष्ट्रीय खाद्य प्रौद्योगिकी उद्यमिता एवं प्रबंधन संस्थान कुंडली-सोनीपत रहे, जिन्होंने किसानों से संवाद कर कृषि-परिवर्तन में नवाचार एवं अनुसंधान को प्रोत्साहन पर जोर दिया।

# मौजगढ़ में विकसित भारत संकल्प यात्रा के तहत जागरूकता कार्यक्रम करवाया किसानों को खरीफ फसलों की नई तकनीकों के बारे में किया जागरूक

महक दत्त/अबोहर

गंज मौजगढ़ में विकसित भारत संकल्प यात्रा के तहत जागरूकता कार्यक्रम हुआ। यह कार्यक्रम विकसित कृषि संकल्प अभियान के अंतर्गत आयोजित किया। आयोजन कृषि विज्ञान केंद्र फॉर्निका, आइसीएआर-सीफेट लुधियाना, पंचम कृषि विश्वविद्यालय और कृषि विभाग पंजाब ने मिलकर किया। कार्यक्रम का उद्देश्य किसानों को खरीफ फसलों को नई तकनीकी प्रणालि और जैविक खेती के तरीकों की जानकारी देना था। कृषि अनुसंधान डॉ. पीके सिंह ने कहा कि जैविक तरीकों को अपनकर खेती खेती से आगे देवतुनी को जा सकती है। उन्होंने किसानों से अपील की कि वे पारंपरिक तरीकों से आगे बढ़ें और नई तकनीकों को अपनाएं।



मौजगढ़ में आयोजित जागरूकता कार्यक्रम में उपस्थित अतिथि और अग्य।

## तकनीक से फसल का मूल्य बढ़ेगा

कार्यक्रम में आइसीएआर-सीफेट लुधियाना के निदेशक डॉ. नचिकेत बोरकाले बोलते हुए स्टार्ट-अप और प्रसंस्करण तकनीकों की जानकारी दी। उन्होंने बताया कि सूखे भंडारण और प्रसंस्करण से फसल का मूल्य बढ़ेगा। इससे किसानों में बेहतर दाम मिल सकता है। आइसीएआर लुधियाना के प्रधान वैज्ञानिक डॉ. मोहा कुमार ने यह जिक्र किया कि फसल को खेती के अंतिम चरण में मक्का की उन्नत किस्मों का व्यावसायिक खेती से अक्षा लाभ मिल सकता है। उन्होंने मक्का को उन्नत किस्मों और वैज्ञानिक खेती के तरीकों की जानकारी दी।

## किसान बोले, कार्यक्रम से मिली नई दिशा

कार्यक्रम में बड़ी संख्या में किसान शामिल हुए। उन्होंने किसानों से सीधे सफल फसल और खेती से जुड़ी अग्रगत तकनीकों की जानकारी लेने का अवसर प्राप्त किया। उन्होंने कहा कि यह कार्यक्रम उनके लिए लाभदायक था। उन्हें खेती के नए तरीकों को समझने का मौका मिला। कार्यक्रम के अंत में किसानों ने अधिकारियों से अग्रगत किसे अग्रगत समझ-समय पर लेने से किसानों को सहायता देना और पंचम कृषि विश्वविद्यालय के अग्रगत कार्यक्रम में भाग लेना। प्रोफेसर के मुताबिक अधिकारी डॉ. राजेंद्र कश्यप और पंचम कृषि विश्वविद्यालय के डॉ. जयदीप शोभा सहित कई अधिकारी भी मौजूद रहे।

# स्वर्णभूमि टाइम्स आईसीएआर-सीफेट में पीएम द्वारा पीएमडीडीकेवाई एवं अन्य योजनाओं के शुभारंभ का सीधा प्रसारण आयोजित

**स्वर्णभूमि टाइम्स न्यूज, लुधियाना (राकेश अरोड़ा):** आईसीएआर-केंद्रीय उपरांत अभियांत्रिकी एवं प्रौद्योगिकी संस्थान (सीफेट), लुधियाना द्वारा संस्थान के कॉन्फ्रेंस हॉल-2 में कृषि एवं किसान कल्याण विभाग की प्रमुख पहलों के शुभारंभ के अवसर पर माननीय प्रधानमंत्री के लाइव प्रसारण कार्यक्रम का सफल आयोजन किया गया। कार्यक्रम के दौरान प्रधानमंत्री धन-धान्य योजना, दाल आत्मनिर्भरता मिशन तथा अन्य प्रमुख योजनाओं को र्टीडिज एवं बैनरों के माध्यम से प्रदर्शित किया गया। किसानों (पुरुष एवं महिला दोनों) को गानों से आमंत्रित कर लाया गया ताकि वे इस महत्वपूर्ण सत्र का प्रत्यक्ष प्रसारण देख सकें। लाइव प्रसारण प्रारंभ होने से पूर्व कृषि एवं किसानों से संबंधित केंद्र सरकार की योजनाओं पर विस्तारपूर्वक चर्चा की गई। किसानों को डी.डी किसान



चैनल के माध्यम से संस्थान की गतिविधियों, कटाई-उपरांत फसल प्रबंधन पहलों तथा आईसीएआर-सीफेट की प्रौद्योगिकियों से संबंधित वीडियो दिखाए गए। इस अवसर पर विकसित कृषि संकल्प अभियान पर भी विचार-विमर्श किया गया। कार्यक्रम में कुल 305 प्रतिभागियों (198 पुरुष एवं 107 महिला) किसान, संस्थान के विस्तारपूर्वक चर्चा की गई। छात्र, कृषि मजदूर तथा अन्य

सहयोग प्रदान किया। डॉ. विकास कुमार ने संस्थान द्वारा संचालित विभिन्न प्रशिक्षण कार्यक्रमों की जानकारी साझा की। डॉ. संदीप दवांगे ने प्रधानमंत्री कृषि धन-धान्य योजना की विशेषताओं पर प्रकाश डाला। डॉ. पंकज कुमार ने दालों एवं दाल प्रसंस्करण के महत्व तथा संबंधित प्रौद्योगिकियों की जानकारी दी। इस अवसर पर सभी हितधारकों को स्वच्छता के महत्व से भी अवगत कराया गया। संस्थान के निदेशक डॉ. नचिकेत कोतवालवाले ने प्रतिभागियों से फसल अवशेष जलाने, फसल हानि एवं भोजन की बर्बादी रोकने का आग्रह किया। कार्यक्रम के पश्चात, हितधारकों ने संस्थान में विकसित विभिन्न प्रौद्योगिकियों का अवलोकन किया। सभी प्रतिभागियों को बीज, पराली डीकंपोजर, जैविक उर्वरक एवं संस्थान की तकनीकी शोषण भी वितरित किए गए।

# सीफेट में किसानों ने देखा पीएम धन-धान्य योजना का सीधा प्रसारण

**कार्यक्रम में सीधा प्रसारण देखते हुए किसान व सीफेट के अधिकारी।**  
**सवेरा न्यूज/धर्मवीर अबोहर :** कृषि विज्ञान केंद्र, क्षेत्रीय केंद्र सीफेट अबोहर द्वारा विशेष कार्यक्रम का आयोजन किया गया, जिसमें प्रधानमंत्री नरेंद्र मोदी द्वारा आरंभ की गई पीएम धन-धान्य योजना व आत्मनिर्भरता मिशन योजनाओं के शुभारंभ का सीधा प्रसारण देखा गया। इस अवसर पर केंद्र परिसर में बड़ी संख्या में किसानों की उपस्थिति रही, जहां लगभग 350 किसानों ने सीफेट रूप से भाग लिया। कार्यक्रम दौरान किसानों को नई योजनाओं की विस्तृत जानकारी प्रदान की गई, जिनका उद्देश्य कृषि क्षेत्र को सशक्त बनाना, किसानों की आय में वृद्धि करना तथा आत्मनिर्भर भारत के लक्ष्य को साकार करना है। विशेषज्ञों ने बताया कि पीएम धन-धान्य योजना के अंतर्गत किसानों को आधुनिक तकनीकों, उन्नत बीजों, फसल विविधीकरण तथा विपणन सुविधाओं से जोड़ने पर विशेष ध्यान दिया गया है। कार्यक्रम में जागसानी, पशुपालन तथा अन्य सहायता विभागों के अधिकारियों ने भी भाग लिया और किसानों को विभिन्न सरकारी योजनाओं, प्रशिक्षण कार्यक्रमों तथा लाभकारी योजनाओं की जानकारी दी। इस अवसर पर क्षेत्रीय केंद्र सीफेट अबोहर के प्रभारी डा. अमित नाथ सहित कृषि विज्ञान केंद्र के सभी वैज्ञानिक व विशेषज्ञ उपस्थित रहे।

# दैनिक सवेरा किसान खुद को उद्यमी के तौर पर स्थापित करें : डा. नाविकेता कोतवाली वाले

**केवीके सीफेट अबोहर में किसान भेला**  
सवेरा न्यूज/धर्मवीर अबोहर : 18 अक्टूबर को कृषि विज्ञान केंद्र, क्षेत्रीय केंद्र सीफेट अबोहर में आयोजित कार्यक्रम का शुभारंभ किया गया। कार्यक्रम में प्रधानमंत्री नरेंद्र मोदी द्वारा आरंभ की गई पीएम धन-धान्य योजना व आत्मनिर्भरता मिशन योजनाओं के शुभारंभ का सीधा प्रसारण देखा गया। इस अवसर पर केंद्र परिसर में बड़ी संख्या में किसानों की उपस्थिति रही, जहां लगभग 350 किसानों ने सीफेट रूप से भाग लिया। कार्यक्रम दौरान किसानों को नई योजनाओं की विस्तृत जानकारी प्रदान की गई, जिनका उद्देश्य कृषि क्षेत्र को सशक्त बनाना, किसानों की आय में वृद्धि करना तथा आत्मनिर्भर भारत के लक्ष्य को साकार करना है। विशेषज्ञों ने बताया कि पीएम धन-धान्य योजना के अंतर्गत किसानों को आधुनिक तकनीकों, उन्नत बीजों, फसल विविधीकरण तथा विपणन सुविधाओं से जोड़ने पर विशेष ध्यान दिया गया है। कार्यक्रम में जागसानी, पशुपालन तथा अन्य सहायता विभागों के अधिकारियों ने भी भाग लिया और किसानों को विभिन्न सरकारी योजनाओं, प्रशिक्षण कार्यक्रमों तथा लाभकारी योजनाओं की जानकारी दी। इस अवसर पर क्षेत्रीय केंद्र सीफेट अबोहर के प्रभारी डा. अमित नाथ सहित कृषि विज्ञान केंद्र के सभी वैज्ञानिक व विशेषज्ञ उपस्थित रहे।